

The T-WALL® Solution

PROJECT: **BATTLEGROUND AVE.**

LOCATION: Greensboro, NC

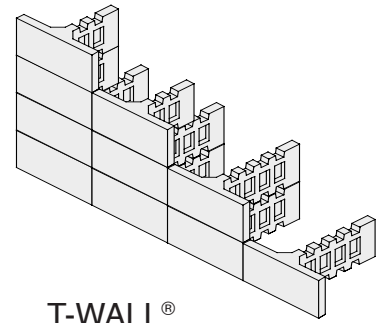

T-WALL®
Retaining Wall System



OWNER: North Carolina
Department of Transportation

PROBLEMS:

- Limited right-of-way
- Construction impact on adjacent properties

SOLUTIONS: T-WALL® was designed to fit within the project space constraints. The rapid, phased construction eliminated the need for temporary excavation support thereby minimizing construction time and reducing the impact on homeowners and traffic.



THE NEEL COMPANY
8328-D Traftord Lane
Springfield, VA 22152
703-913-7858

www.neelco.com